

TEMPLATE FOR

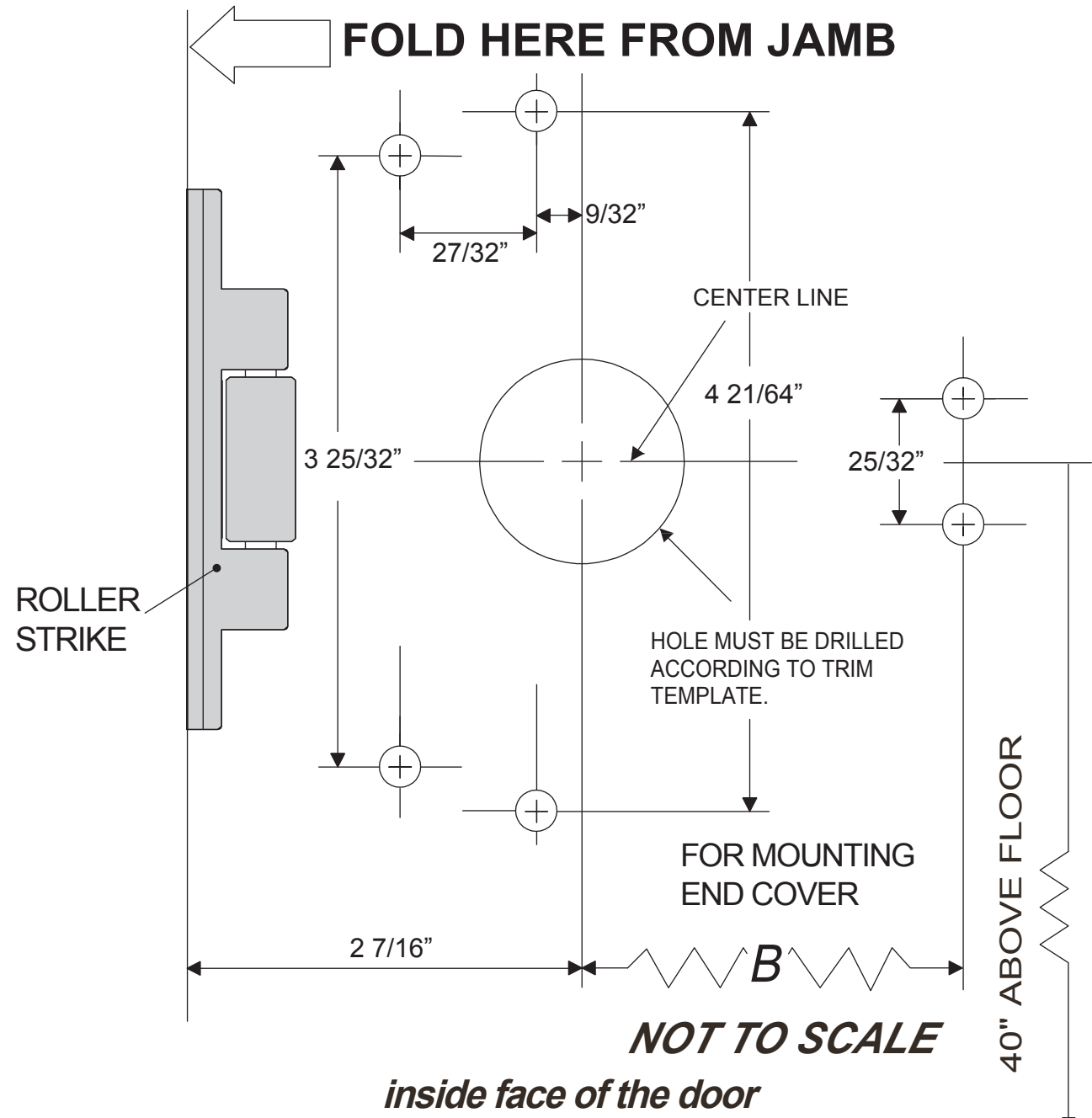
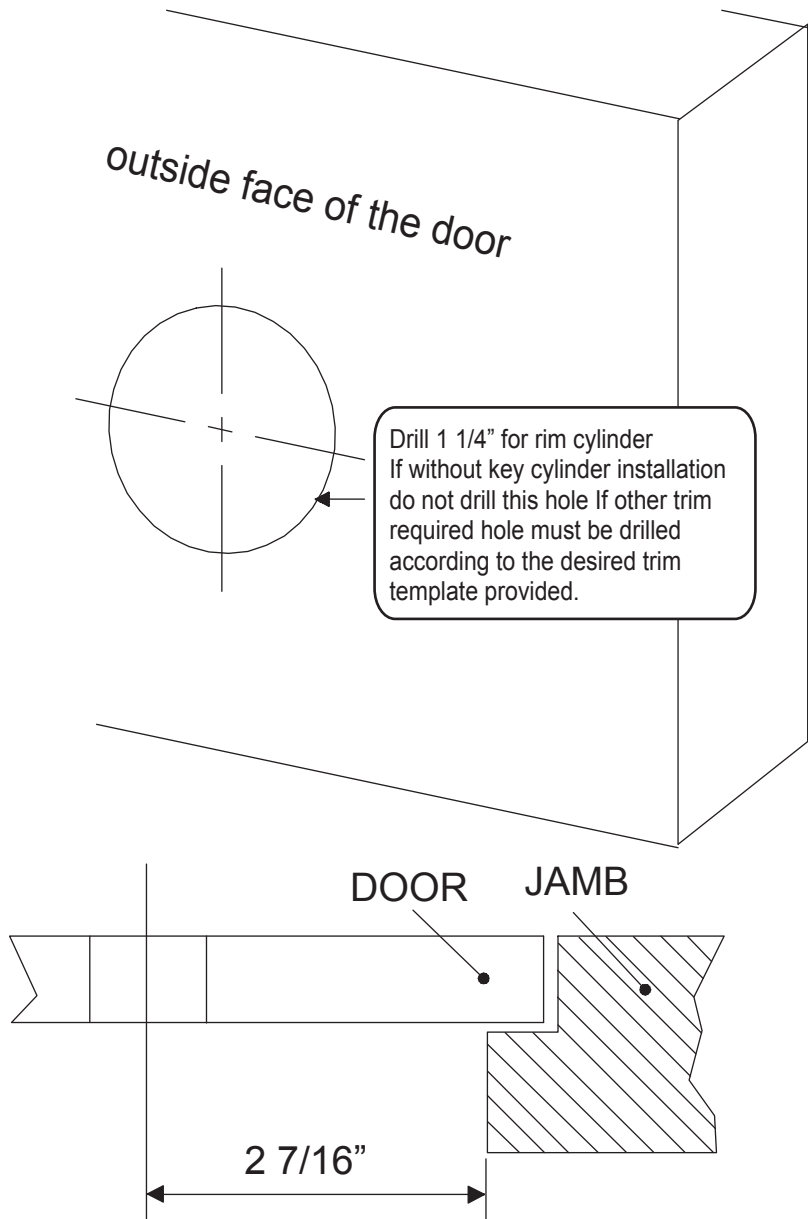

- (A) For A-UL500XR (UL Listed)-Drill & tap for (6) 1/4"x20 machine screws for exit device and drill & tap for (3) 1/4"x20 machine screws for Roller Strike
- (B) For A-F5000XR (Fire Rated)-Drill 9/32" holes inside and 3/8" holes outside for the (6) thru bolts and drill & tap for (3) 1/4"x20 machine screws for Roller Strike.